

**thermaline S90** **STANDKOCHKESSEL, RUND, GAS**  
**STATIONARY BOILING PANS, ROUND, GAS**  
**PENTOLE FISSE, TONDA, A GAS**  
**MARMITES FIXES, RONDE, POUR GAZ**

<b>MODEL CODE / PNC</b>
freistehend, free standing, isolato, isolé einseitig bedienbar, operated from one side, comando da un lato, utilisable d'un côté
AVRBOA0000 / 582452
AVRCOA0000 / 582453
AVREOA0000 / 582454
AVRBOAT000 / 582458
AVRCOAT000 / 582459
AVREOAT000 / 582460

an Wand, against wall, contro la parete, contre cloison
AVRBOFO000 / 582455
AVRCOFO000 / 582456
AVREOFO000 / 582457
AVRBOFT000 / 582461
AVRCOFT000 / 582462
AVREOFT000 / 582463

Series No.: starting from 537...

---

**DE ERSATZTEILLISTE**  
**GB SPARE PARTS LIST**  
**IT LISTA DEI PEZZI DI RICAMBIO**  
**FR LISTE DES PIÈCES DE RECHANGE**

---

doc.	62.9681.02
edition	4
dat.	10.2005

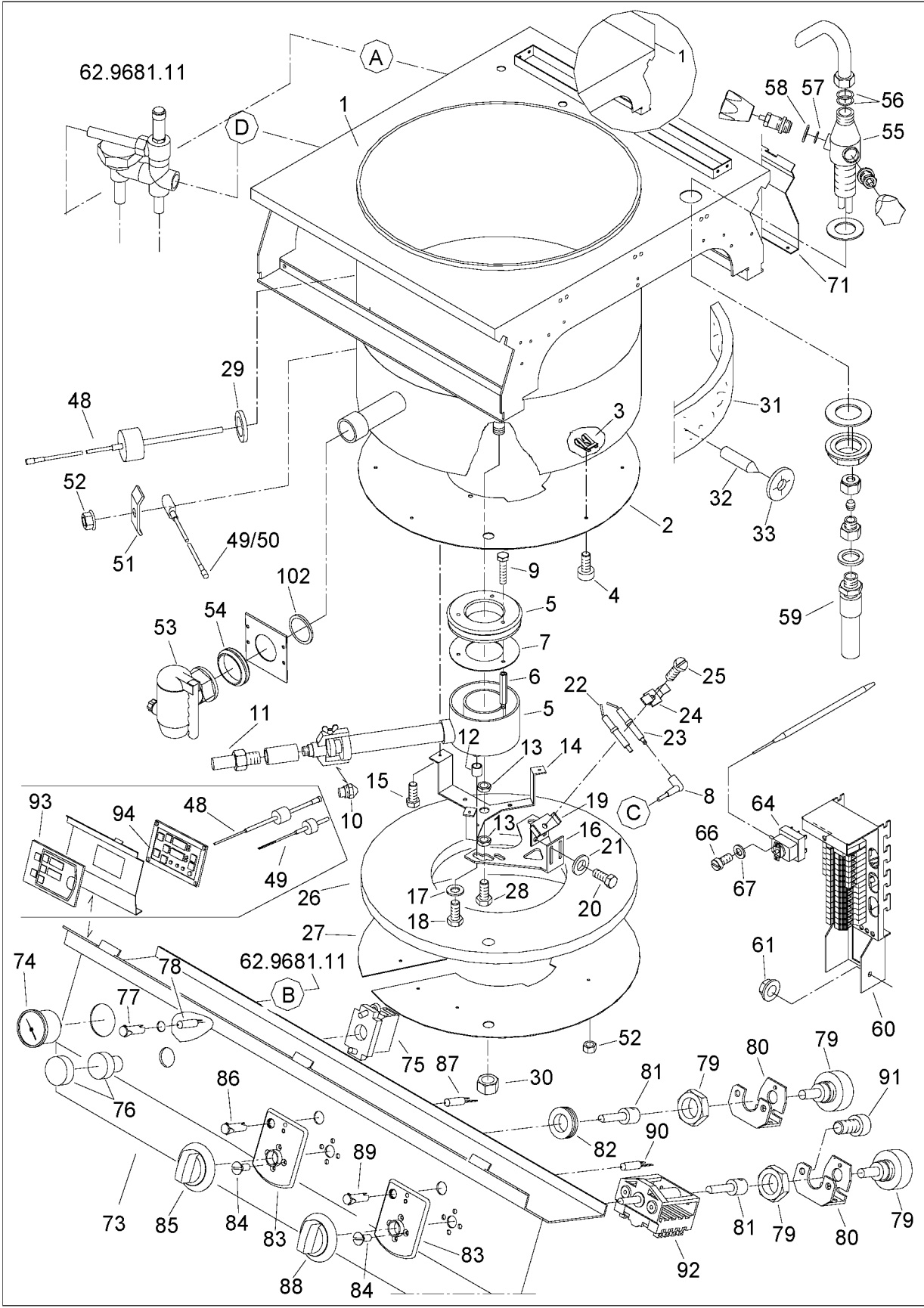

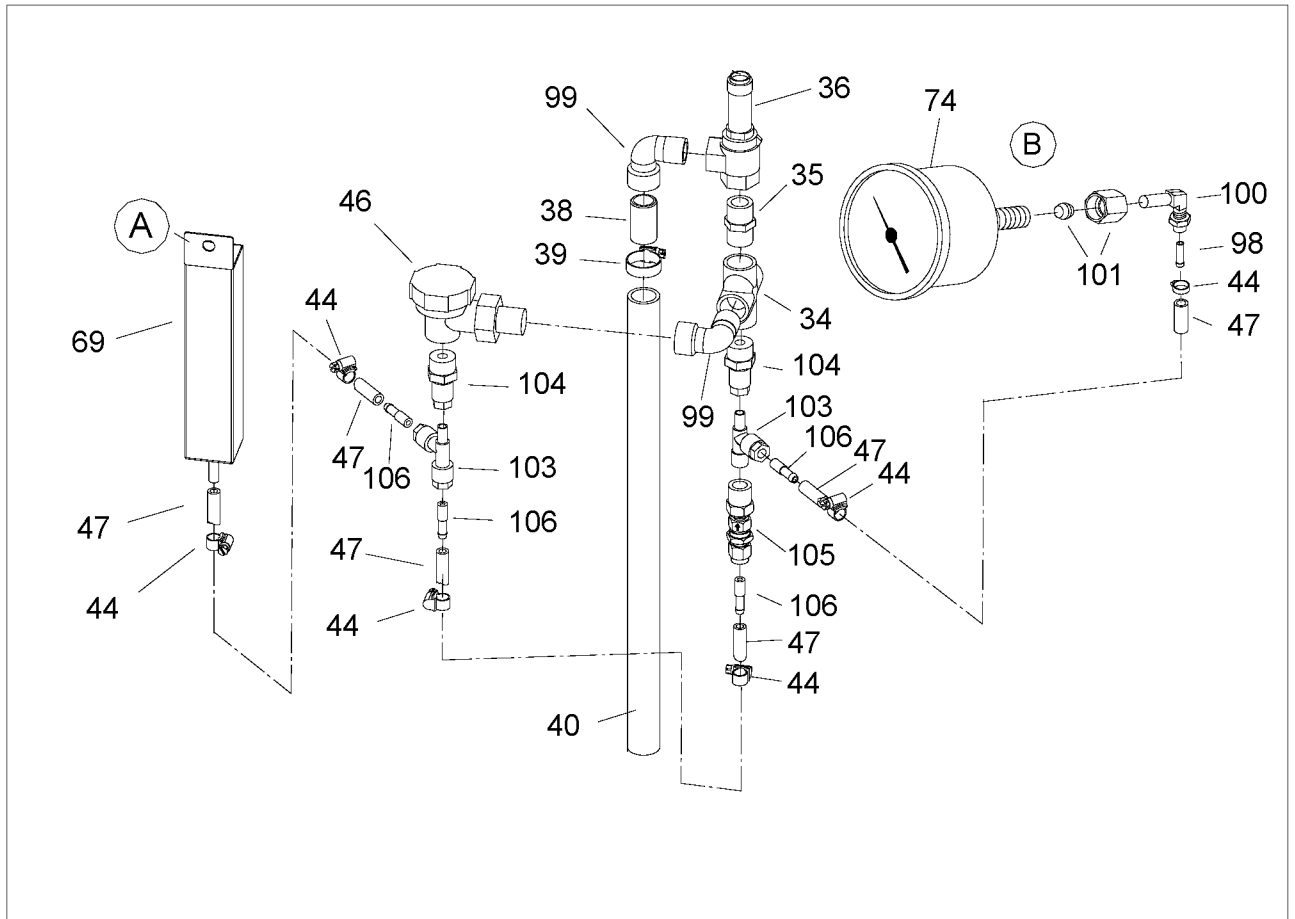

Electromechanical Control

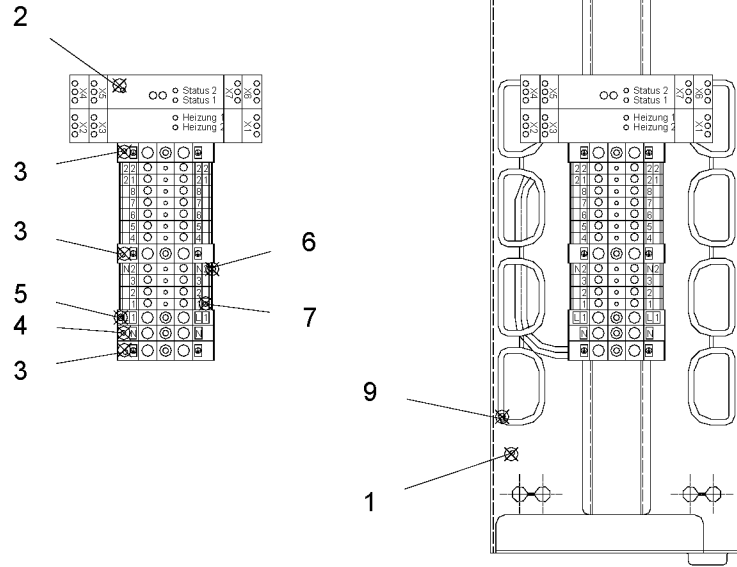

Electrical Control

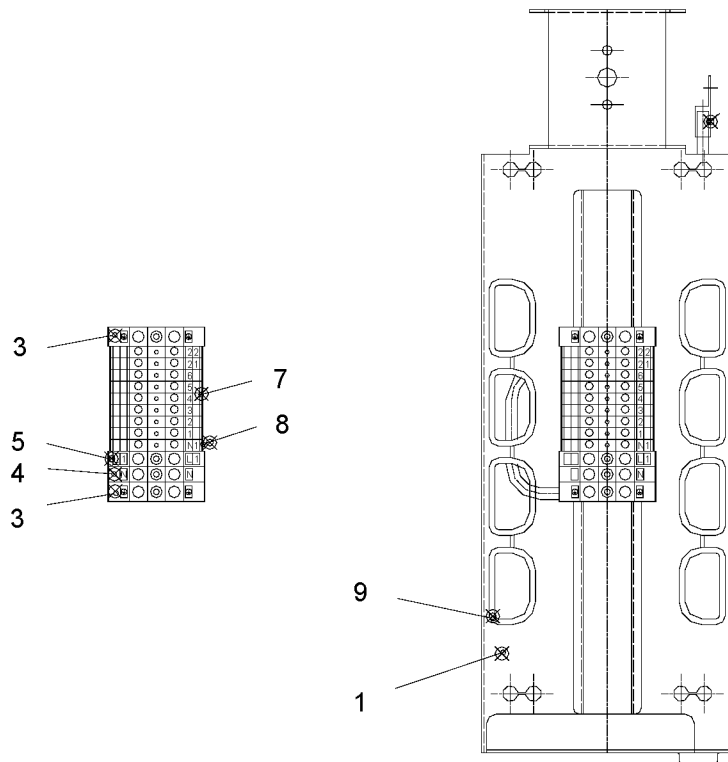

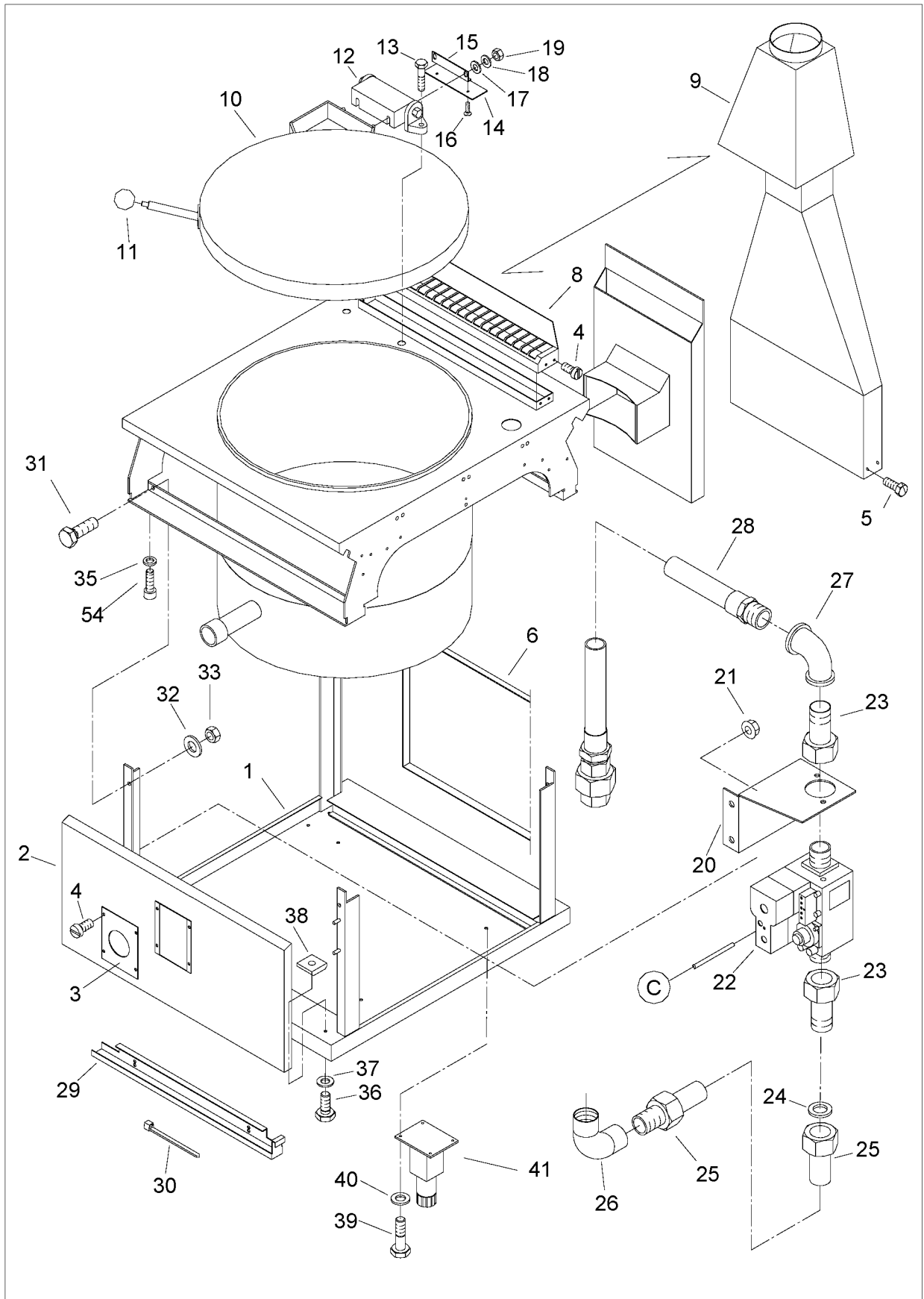

## Stationary boiling pan Gas heated 60 Liter (15.0 kW) thermaline S90

		Gas type	Nominal pressure	Category	Main flame		Air adjustment Distance X	Servo-Pressure Regulator	SLOW OPENING
					mm	No.			
Natural gases	1	Natural gas H	18-20 / 20	2H	3.40	71.4160.340	13	10.0	0
	2	Natural gas E	20	2E	3.40	71.4160.340	13	10.0	0
	3	Natural gas H / L	20 / 25	2+	2.80	71.4160.280	13	inactive	0
	4	Natural gas L	25	2L	3.40	71.4160.340	9	15.0	0
	5	Natural gas LL	20	2LL	3.40	71.4160.340	9	15.0	0
Liquid gases	6	Propane	30	3P	2.00	71.4160.200	15	inactive	180
	7		37	3P	1.90	71.4160.190	15	inactive	180
	8		50	3P	1.80	71.4160.180	14	inactive	180
	9	Butane/Propane	28 - 30	3B/P	1.90	71.4160.190	15	inactive	180
	10		50	3B/P	1.60	71.4160.160	15	inactive	180
	11		28-30 / 37	3+	1.90	71.4160.190	15	inactive	180
	12	Pressure pair	50 / 67	3+	1.60	71.4160.160	15	inactive	180

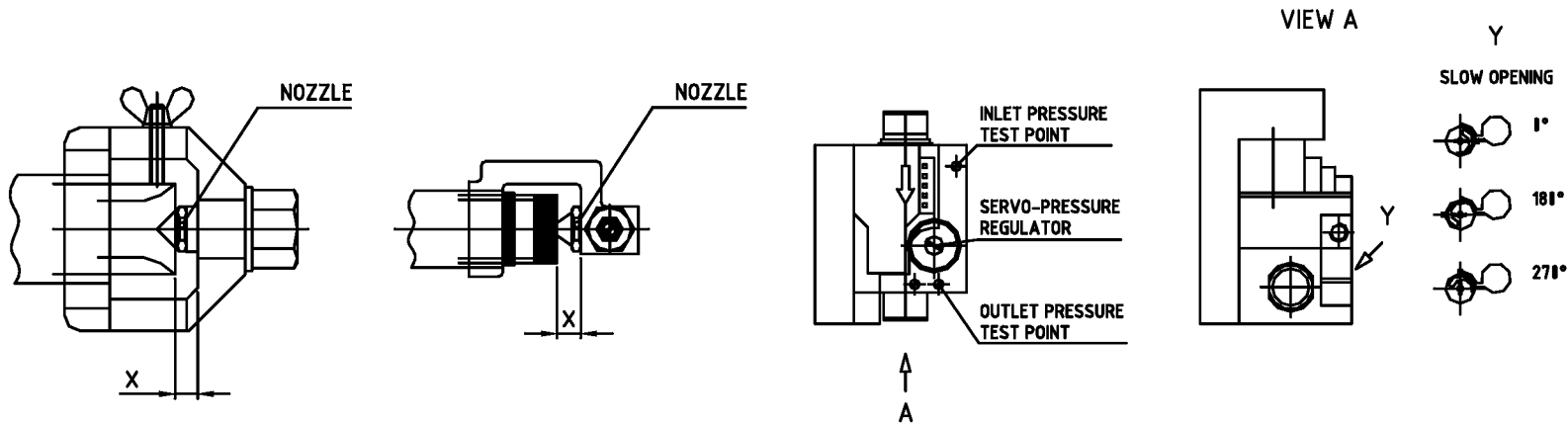

## Stationary boiling pan Gas heated 80 Liter (18.0 kW) thermaline S90

		Gas type	Nominal pressure	Category	Main flame		Air adjustment Distance X	Servo-Pressure Regulator	SLOW OPENING
					mm	No.			
Natural gases	1	Natural gas H	18-20 / 20	2H	3.60	71.4160.360	13	10.0	0
	2	Natural gas E	20	2E	3.60	71.4160.360	13	10.0	0
	3	Natural gas H / L	20 / 25	2+	3.10	71.4160.310	12	inactive	0
	4	Natural gas L	25	2L	3.60	71.4160.360	11	15.0	0
	5	Natural gas LL	20	2LL	3.60	71.4160.360	11	15.0	0
Liquid gases	6	Propane	30	3P	2.20	71.4160.220	14	inactive	180
	7		37	3P	2.15	71.4160.215	14	inactive	180
	8		50	3P	1.95	71.4160.195	14	inactive	180
	9	Butane/Propane	28 - 30	3B/P	2.15	71.4160.215	14	inactive	180
	10		50	3B/P	1.85	71.4160.185	14	inactive	180
	11	Butane/Propane	28-30 / 37	3+	2.15	71.4160.215	14	inactive	180
	12	Pressure pair	50 / 67	3+	1.85	71.4160.185	14	inactive	180

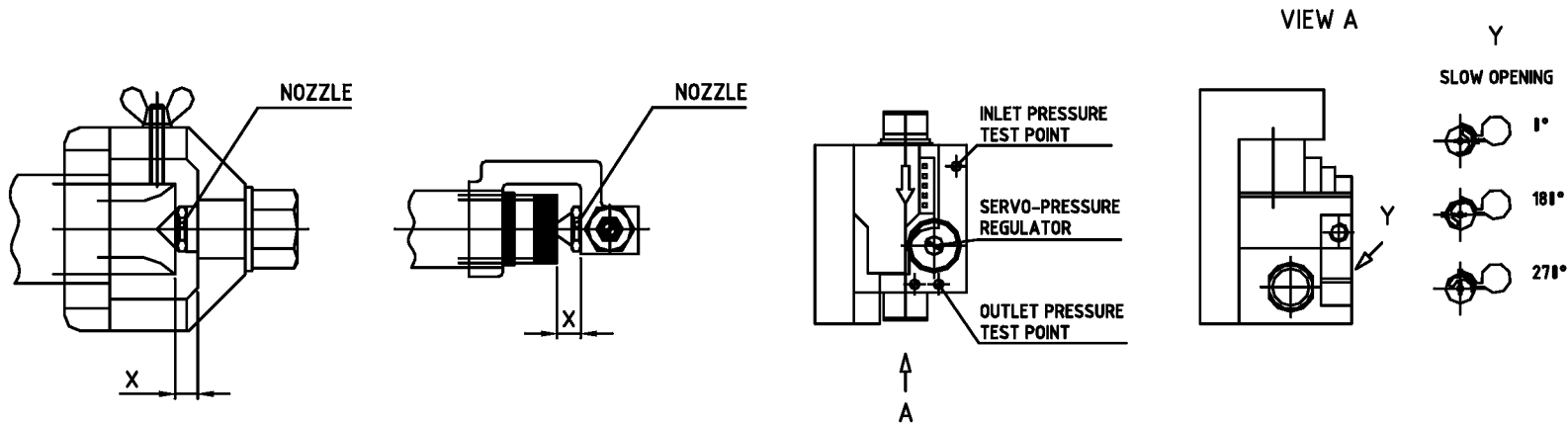

## Stationary boiling pan Gas heated 100 Liter (21.0 kW) thermaline S90

		Gas type	Nominal pressure	Category	Main flame		Air adjustment Distance X	Servo-Pressure Regulator	SLOW OPENING
					mm	No.			
Natural gases	1	Natural gas H	18-20 / 20	2H	3.90	71.4160.390	18	10.0	0
	2	Natural gas E	20	2E	3.90	71.4160.390	18	10.0	0
	3	Natural gas H / L	20 / 25	2+	3.90	71.4160.390	18	inactive	0
	4	Natural gas L	25	2L	3.90	71.4160.390	18	15.0	0
	5	Natural gas LL	20	2LL	3.90	71.4160.390	18	15.0	0
Liquid gases	6	Propane	30	3P	2.40	71.4160.240	15	inactive	180
	7		37	3P	2.30	71.4160.230	15	inactive	180
	8		50	3P	2.10	71.4160.210	15	inactive	180
	9	Butane/Propane	28 - 30	3B/P	2.30	71.4160.230	15	inactive	180
	10		50	3B/P	1.95	71.4160.195	11	inactive	180
	11		28-30 / 37	3+	2.30	71.4160.230	15	inactive	180
	12		50 / 67	3+	1.95	71.4160.195	11	inactive	180

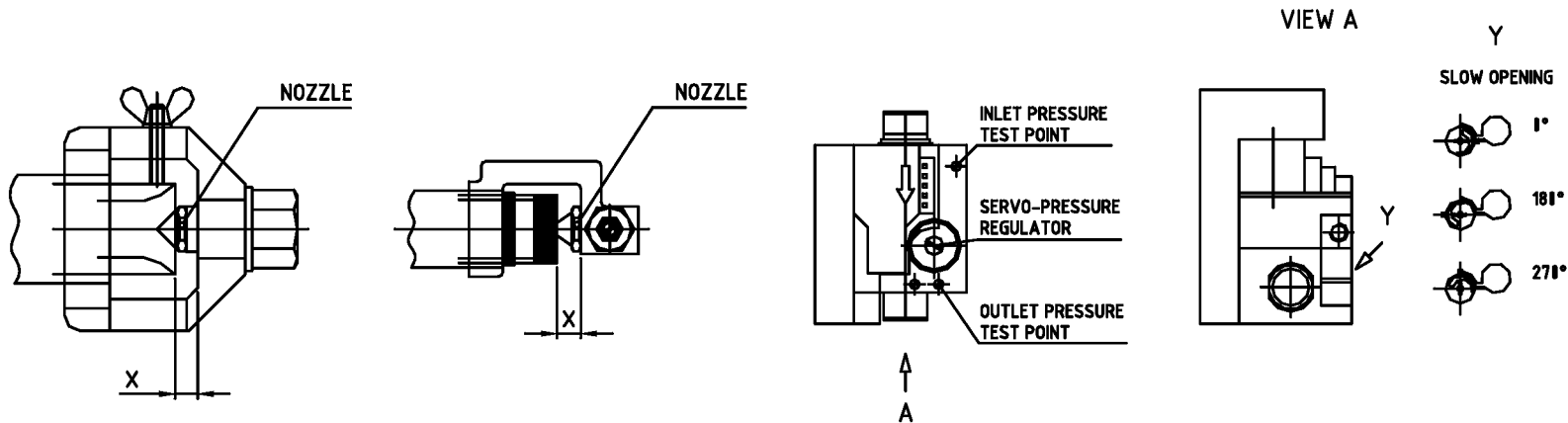



**thermaline S90** **STANDKOCHKESSEL, RUND, GAS**  
**STATIONARY BOILING PANS, ROUND, GAS**  
**PENTOLE FISSE, TONDA, A GAS**  
**MARMITES FIXES, RONDE, POUR GAZ**

<b>MODEL CODE / PNC</b>
freistehend, free standing, isolato, isolé einseitig bedienbar, operated from one side, comando da un lato, utilisable d'un côté
AVRBOA0000 / 582452
AVRCOA0000 / 582453
AVREOA0000 / 582454
AVRBOA0000 / 582458
AVRCOA0000 / 582459
AVREOA0000 / 582460

an Wand, against wall, contro la parete, contre cloison
AVRBOFO000 / 582455
AVRCOFO000 / 582456
AVREOFO000 / 582457
AVRBOFT000 / 582461
AVRCOFT000 / 582462
AVREOFT000 / 582463

**DE ERSATZTEILLISTE**  
**GB SPARE PARTS LIST**  
**IT LISTA DEI PEZZI DI RICAMBIO**  
**FR LISTE DES PIÈCES DE RECHANGE**

doc.	62.9681.02
edition	1
dat.	05.2003

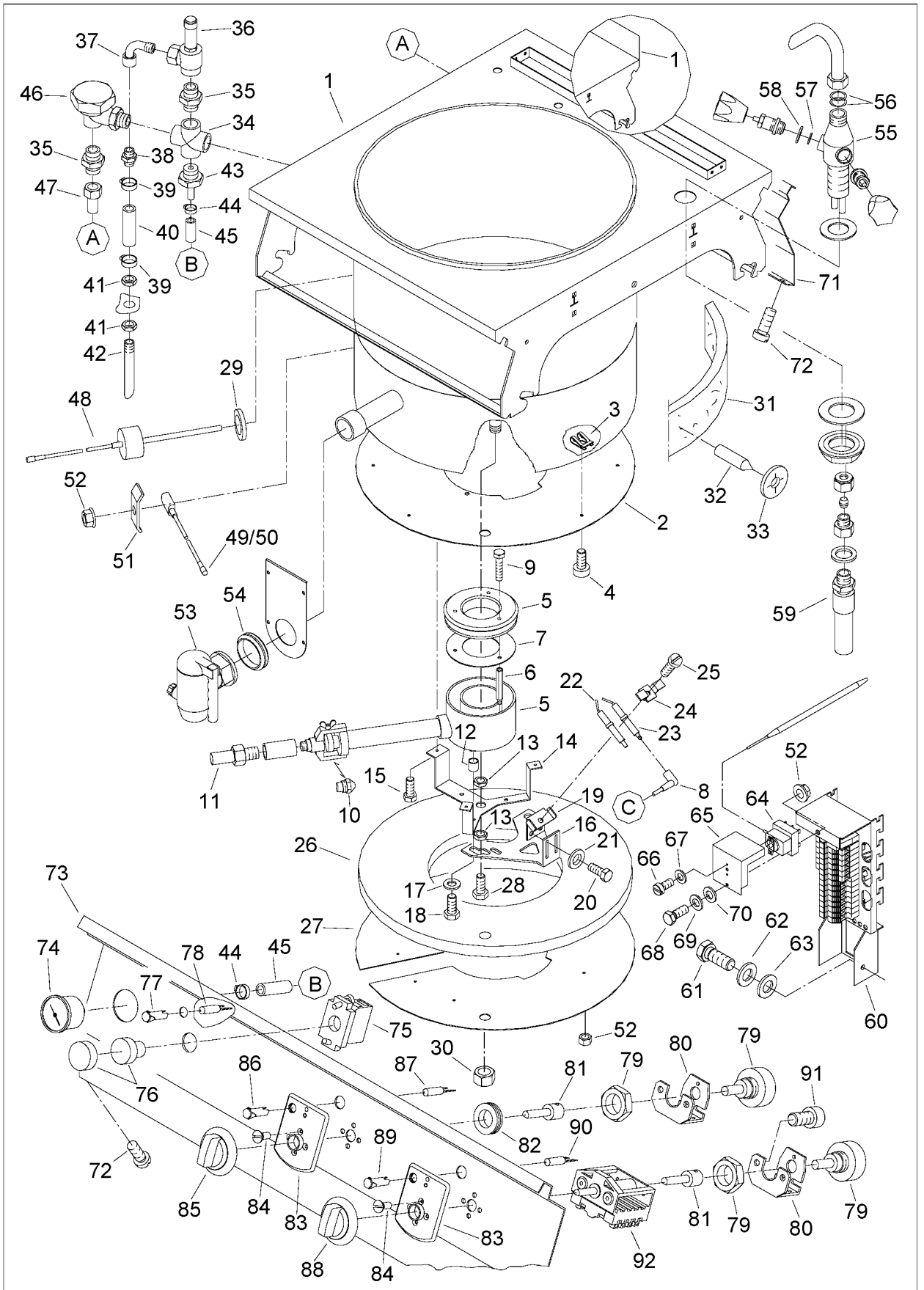

62.9681.02-1		DE	GB	IT	FR						
		Bezeichnung	designation	designazione	désignation						
		Standkochkessel, Gas	stationary boiling pan, gas	pentola fissa, gas	marmite fixe, gaz	60l		80l		100l	
Pos.	Product No.	Gestell	frame	telaio	cadre	E	W	E	W	E	W
1	77.4728.01	Kessel 60l mit Mischbatterie	boiling pan 60 lt with mixer unit	pentola 60 lt con batteria erog. acqua	marmite 60 lt avec mitigeur		1				
	77.4728.02	Kessel 80l mit Mischbatterie	boiling pan 80 lt with mixer unit	pentola 80 lt con batteria erog. acqua	marmite 80 lt avec mitigeur				1		
	77.4728.03	Kessel100l mit Mischbatterie	boiling pan 100 lt with mixer unit	pentola 100 lt con batteria erog. acqua	marmite 100 lt avec mitigeur						1
	77.4728.04	Kessel 60l ohne Mischbatterie	boiling pan 60 lt without mixer unit	pentola 60 lt senza batteria erog. acqua	marmite 60 lt sans mitigeur		1				
	77.4728.05	Kessel 80l ohne Mischbatterie	boiling pan 80 lt without mixer unit	pentola 80 lt senza batteria erog. acqua	marmite 80 lt sans mitigeur				1		
	77.4728.06	Kessel100l ohne Mischbatterie	boiling pan 100 lt without mixer unit	pentola 100 lt senza batteria erog. acqua	marmite 100 lt sans mitigeur						1
	77.4728.11	Kessel 60l mit Mischbatterie	boiling pan 60 lt with mixer unit	pentola 60 lt con batteria erog. acqua	marmite 60 lt avec mitigeur	1					
	77.4728.12	Kessel 80l mit Mischbatterie	boiling pan 80 lt with mixer unit	pentola 80 lt con batteria erog. acqua	marmite 80 lt avec mitigeur			1			
	77.4728.13	Kessel100l mit Mischbatterie	boiling pan 100 lt with mixer unit	pentola 100 lt con batteria erog. acqua	marmite 100 lt avec mitigeur						1
	77.4728.14	Kessel 60l ohne Mischbatterie	boiling pan 60 lt without mixer unit	pentola 60 lt senza batteria erog. acqua	marmite 60 lt sans mitigeur	1					
	77.4728.15	Kessel 80l ohne Mischbatterie	boiling pan 80 lt without mixer unit	pentola 80 lt senza batteria erog. acqua	marmite 80 lt sans mitigeur			1			
	77.4728.16	Kessel100l ohne Mischbatterie	boiling pan 100 lt without mixer unit	pentola 100 lt senza batteria erog. acqua	marmite 100 lt sans mitigeur						1
2	76.4838	Deckblech Brennkammer	cover plate combustion chamber	lamiera di copertura camera di combustione	tôle de couverture chambre de combustion	1	1				
	76.4839	Deckblech Brennkammer	cover plate combustion chamber	lamiera di copertura camera di combustione	tôle de couverture chambre de combustion			1	1		
	77.4726	Deckblech Brennkammer 100l	cover plate combustion chamber	lamiera di copertura camera di combustione	tôle de couverture chambre de combustion					1	1
3	712 044 121.01	Steckmutter 4.8	lock nut 4.8	dado a innesto 4.8	écrou à embrocher 4.8	8	8	8	8	8	8
4	1 701 7535	Schraube 4.8x9.5	screw 4.8x9.5	vite 4.8x9.5	vis 4.8x9.5	8	8	8	8	8	8
5	76.3700	Gasbrenner	gas burner	becco del gas	brûleur à gaz	1	1				
	76.3701	Gasbrenner	gas burner	becco del gas	brûleur à gaz			1	1		
	77.3700	Gasbrenner	gas burner	becco del gas	brûleur à gaz					1	1

62.9681.02-1		DE	GB	IT	FR						
		Bezeichnung	designation	designazione	désignation						
		Standkochkessel, Gas	stationary boiling pan, gas	pentola fissa, gas	marmite fixe, gaz	60I		80I		100I	
Pos.	Product No.	Gestell	frame	telaio	cadre	E	W	E	W	E	W
6	71.2096.11	Distanzbolzen	spacer bolt	bullone di distanza	boulon de distance	3	3				
	71.2096.12	Distanzbolzen	spacer bolt	bullone di distanza	boulon de distance			3	3		
	71.2096.01	Distanzbolzen	spacer bolt	bullone di distanza	boulon de distance			1	1		
7	76.4837.01	Brennersieb	burner strainer	staccio del bruciatore	tamis de brûleur	1	1				
	76.4837.02	Brennersieb	burner strainer	staccio del bruciatore	tamis de brûleur			1	1		
	76.4837.03	Brennersieb	burner strainer	staccio del bruciatore	tamis de brûleur					1	1
8	77.3011.01	Zündkabel	ignition cable	cavo dell'accenditore	câble d'allumage	1	1	1	1	1	1
9	1 701 2516	Schraube M6x25	screw M6x25	vite M6x25	vis M5X12			1	1		
	1 701 2593	Schraube M6x25	screw M6x25	vite M6x25	vis M6X12	1	1				
10	71.4160.XX	Düse XX: siehe Düsentabelle	nozzle XX: see table of nozzle	ugello XX: vedere tabella di ugello	gicleur XX: voir tableau de gicleur	1	1	1	1	1	1
11	77.4731.01	Gaszuleitung	gas conduction	conduttura di gas	conduite de gaz	1	1	1	1	1	1
12	76.4976	Distanzbolzen	spacer bolt	bullone di distanza	boulon de distance					3	3
13	1 102 2401	Mutter	nut	dado	écrou	2	2	2	2	2	2
14	76.4842.01	Brennerhalter	burner support	supporto del bruciatore	support de brûleur	1	1				
	76.4842.02	Brennerhalter	burner support	supporto del bruciatore	support de brûleur			1	1		
	76.4722.03	Brennerhalter	burner support	supporto del bruciatore	support de brûleur					1	1
15	1 701 2525	Schraube M8x16	screw M8x16	vite M8x16	vis M8x16	3	3	3	3	3	3
16	76.4982	Halter	support	sostegno	fixation	1	1	1	1	1	1
17	1 701 3545	Unterlagscheibe 6.4x18x1.6	washer 6.4x18x1.6	rondella 6.4x18x1.6	rondelle 6.4x18x1.6	3	3				
	1 701 3547	Unterlagscheibe 6.4x24x1.6	washer 6.4x24x1.6	rondella 6.4x24x1.6	rondelle 6.4x24x1.6			3	3		
	1 701 3516	Unterlagscheibe 10.4x30x2	washer 10.4x30x2	rondella 10.4x30x2	rondelle 10.4x30x2					3	3
18	1 701 2569	Schraube M6x16	screw M6x16	vite M6x16	vis M6X12	3	3				
	1 701 2525	Schraube M8x25	screw M8x25	vite M8x25	vis M8X12			3	3		
	1 701 2612	Schraube M10x30	screw M10x30	vite M10x30	vis M8X12					3	3
19	76.4984	Halter	support	sostegno	fixation	1	1	1	1	1	1
20	1 701 2572	Schraube M6x10	screw M6x10	vite M6x10	vis M6X10	5	5	5	5	2	2
21	1 701 4003	Unterlagscheibe 6.4x12x1.6	washer 6.4x12x1.6	rondella 6.4x12x1.6	rondelle 6.4x12x1.6	3	3	3	3		
22	76.3709	Masseelektrode	earth electrode	elettrodo, terra	électrode de la terre	1	1	1	1	1	1
23	76.3710	Kombielektrode	combination electrode	elettrodo di combinazione	électrode de combinaison	1	1	1	1	1	1
24	72.2318	Gegenhalter	counter support	contro-sostegno	contre-fixation	1	1	1	1	1	1
25	10 3179	Schraube M5x9	screw M5x9	vite M5x9	vis M5x9	1	1	1	1	1	1

62.9681.02-1		DE	GB	IT	FR						
		Bezeichnung	designation	designazione	désignation						
		Standkochkessel, Gas	stationary boiling pan, gas	pentola fissa, gas	marmite fixe, gaz	60l	80l	100l			
Pos.	Product No.	Gestell	frame	telaio	cadre	E	W	E	W	E	W
26	76.4845.01	Brennerplatte	burner plate	placca del bruciatore	plaque de brûleur	1	1				
	76.4845.02	Brennerplatte	burner plate	placca del bruciatore	plaque de brûleur			1	1		
	76.4845.03	Brennerplatte	burner plate	placca del bruciatore	plaque de brûleur					1	1
27	76.4937.01	Isolation, Deckblech	isolation, cover plate	isolamento, lamiera di copertura	insulation, tôle de couverture	1	1				
	76.4937.02	Isolation, Deckblech	isolation, cover plate	isolamento, lamiera di copertura	insulation, tôle de couverture			1	1		
27	76.4937.03	Isolation, Deckblech	isolation, cover plate	isolamento, lamiera di copertura	insulation, tôle de couverture					1	1
28	1 101 3903	Verschlusschraube	lock screw	vite di chiusura	vis de fermeture	1	1	1	1	1	1
30	712 344 853.09	Kappe	cap	cappa	capuchon	1	1	1	1	1	1
31	76.4846.01	Isolation	isolation	isolamento	insulation	1	1				
	76.4846.02	Brandmatte	burner mat	stuoia del bruciatore	tapis de brûleur			1	1		
	76.4846.06	Brandmatte	burner mat	stuoia del bruciatore	tapis de brûleur					1	1
32	1 201 1959	Nagel, Isolation 30mm	nail isolation 30mm	chiodo isolamento 30mm	clouinsulation 30mm	4	4	4	4	8	8
33	1 201 1961	Clips	clamp sheet	lamiera serrante	tôle de serrage	4	4	4	4	8	8
34	1 116 1167	Kreuzstück	cross piece	pezzo a croce	pièce croisé	1	1	1	1	1	1
35	1 116 1166	Nippel	nipple	raccordo	mamelon	2	2	2	2	2	2
36	76.4462	Sicherheitsventil	safety valve	valvola di sicurezza	soupape de sécurité	1	1	1	1	1	1
37	12 5021	Winkel	angle	angolo	angle	1	1	1	1	1	1
38	712 344 868.04	Nippel 1/2"x35	nipple 1/2"x35	raccordo 1/2"x35	mamelon 1/2"x35	1	1	1	1	1	1
39	1 103 1170	Schlauchklemme	hose clamp	morsa per tubo	pince de serrage	1	1	1	1	1	1
40	1 115 1417	Schlauch 20/26 Silikon	hose 20/26 silicone	tubo flessibile 20/26 silicone	tuyau flexible 20/26 silicone	1	1	1	1	1	1
41	712 344 858.02	Mutter 1/2"	nut 1/2"	dado 1/2"	écrou 1/2"	2	2	2	2	2	2
42	77.0107	Führungsrohr	guide tube	tubo di guida	tuyau de guidage	1	1	1	1	1	1
43	1 116 1168	Nippel	nipple	raccordo	mamelon	1	1	1	1	1	1
44	12 9924	Schlauchklemme	hose clamp	morsa per tubo	pince de serrage	2	2	2	2	2	2
45	12 9043	Schlauch Silikon	hose silicone	tubo flessibile silicone	tuyau flexible silicone	1	1	1	1	1	1
46	1 201 2065	Entlüftungsventil	deaeration valve	valvola d'aerazione	soupape d'aération	1	1	1	1	1	1
47	76.8062.02	Ablaufleitung	drain conduit	conduttura di scarico	conduite d'écoulement	1	1	1	1	1	1
48	77.3007.01	Sensor	sensor	sensore	sonde	1	1	1	1	1	1
49	77.3006.01	Kochgutfühler	food sensor	sensore del cibo	sonde pour aliments	1	1	1	1	1	1
50	1 201 1510	Wärmeleitpaste	heat-conductive paste	pasta d'orientamento di calore	pâte de guidage de chaleur	1	1	1	1	1	1

62.9681.02-1		DE	GB	IT	FR						
		Bezeichnung	designation	designazione	désignation						
		Standkochkessel, Gas	stationary boiling pan, gas	pentola fissa, gas	marmite fixe, gaz	60I		80I		100I	
Pos.	Product No.	Gestell	frame	telaio	cadre	E	W	E	W	E	W
51	76.4191	Halter	support	sostegno	fixation	1	1	1	1	1	1
52	712 044 120.06	Kepsmutter M6	capture nut M6	dado M6	écrou M6	7	7	7	7	7	7
53	1 117 1258	Auslaufhahn 2"	drain valve 2"	rubinetto di scarico 2"	robinet d'écoulement 2"	1	1	1	1	1	1
	1 117 1261	Griff und Feder Auslaufhahn 2"	knob and spring drain valve 2"	manetta e molla rubinetto di scarico 2"	poignée et ressort robinet d'écoulement 2"	1	1	1	1	1	1
54	10 3518	Manschette	seal	guarnizione anulare	manchette	1	1	1	1	1	1
55	77.3008	Mischbatterie	mixer unit	batteria erogazione acqua	mitigeur	1	1	1	1	1	1
56	1 201 2061	O-Ring	o-ring	anello	joint torique	2	2	2	2	2	2
57	1 201 2063	Dichtung	sealing	guarnizione	joint	2	2	2	2	2	2
58	1 201 2062	O-Ring	o-ring	anello	joint torique	2	2	2	2	2	2
59	712 344 893.02	Schlauch	hose	tubo flessibile	tuyau flexible	2	2	2	2	2	2
60	77.9702	Klemme	terminal	morsa	borne	1	1	1	1	1	1
61	1 701 2507	Schraube M5x10	screw M5x10	vite M5x10	vis M5x10	2	2	2	2	2	2
62	1 701 5004	Federring	spring ring	anello della molla	anneau de ressort	2	2	2	2	2	2
63	1 701 3535	Unterlagscheibe M5	washer M5	rondella M5	rondelle M5	2	2	2	2	2	2
64	76.3705	Temperaturbegrenzer	temperature limiter	limitatore di temperatura	limiteur de température	1	1	1	1	1	1
65	77.6001	Befestigungsblech	mounting plate	lamiera	tôle de fixation	1	1	1	1	1	1
66	1 701 1041	Schraube M4x6	screw M4x6	vite M4x6	vis M4x6	2	2	2	2	2	2
67	1 701 7060	Fächerscheibe	serrated lock washer	rondella serrante	rondelle de serrage	2	2	2	2	2	2
68	1 701 2600	Schraube M6x12	screw M6x12	vite M6x12	vis M6x12	1	1	1	1	1	1
69	1 701 5007	Federring M6	spring ring M6	anello della molla M6	anneau de ressort M6	3	3	3	3	3	3
70	1 701 4003	Unterlagscheibe M6	washer M6	rondella M6	rondelle M6	3	3	3	3	3	3
71	62.4000	Blende	filler	copertura	bandeau	1					
	62.4001	Blende	filler	copertura	bandeau			1			
	62.4002	Blende	filler	copertura	bandeau					1	
72	1 701 1069	Schraube M5x12	screw M5x12	vite M5x12	vis M5x12	6	6	6	6	8	8
73	77.1703	Blende	filler	copertura	bandeau	1	1				
	77.1704	Blende	filler	copertura	bandeau			1	1		
	77.1705	Blende	filler	copertura	bandeau					1	1
74	1 201 2066	Manometer	pressure gauge	manometro	manomètre	1	1	1	1	1	1
75	71.6997.02	Entriegelungsschalter	resetting switch	commutatore d.eliminazione disturbi reset switch	commutateur d. réarmement	1	1	1	1	1	1
76	71.6997.01	Entstörtaste mit Schutzkappe	reset button with protection hood	pulsante eliminaz. Guasti con cappa di protezione	touche de deserrage avec capuchon de protection	1	1	1	1	1	1
77	72.5938.09	Lampenfassung rot	lamp socket red	supporto d. lampada rosso	douille de lampe rouge	1	1	1	1	1	1
78	72.5938.03	Lampe	lamp	lampada	lampe	1	1	1	1	1	1

62.9681.02-1		DE	GB	IT	FR						
		Bezeichnung	designation	designazione	désignation						
		Standkochkessel, Gas	stationary boiling pan, gas	pentola fissa, gas	marmite fixe, gaz	60l		80l		100l	
Pos.	Product No.	Gestell	frame	telaio	cadre	E	W	E	W	E	W
79	77.9273.01	Regler	regulator	regolatore	régulateur	2	2	2	2	2	2
80	77.9274	Befestigungswinkel	fixation angle	angolo di fissaggio	équerre de fixation	1	1	1	1	1	1
81	77.9275	Zwischenstück	partition tube	membro intermedio	pièce intermédiaire	2	2	2	2	2	2
82	712 044 961.05	Tülle	socket	isolatore passante	bec verseur	1	1	1	1	1	1
83	62.3577	Grundplatte	base plate	lamiera di fondo	tôle de base	2	2	2	2	2	2
84	1 701 1028	Schraube M4x12	screw M4x12	vite M4x12	vis M4x12	4	4	4	4	4	4
85	77.3101	Drehknopf	knob	manetta di rotazione	bouton rotatif	1	1	1	1	1	1
86	72.5938.07	Lampenfassung	lamp socket	supporto d. lampada	douille de lampe	1	1	1	1	1	1
87	72.5938.03	Lampe	lamp	lampada	lampe	1	1	1	1	1	1
88	77.3701	Drehknopf	knob	manetta di rotazione	bouton rotatif	1	1	1	1	1	1
89	72.5938.08	Lampenfassung grün	lamp socket green	supporto d. lampada verde	douille de lampe vert	1	1	1	1	1	1
90	72.5938.04	Lampe grün	lamp green	lampada verde	lampe vert	1	1	1	1	1	1
91	1 101 1870	Schraube M4x8	screw M4x8	vite M4x8	vis M4x8	2	2	2	2	2	2
92	712 344 152	Vorsetzschalter	series switch	interruttore aggiunto	interrupteur amont	1	1	1	1	1	1
E		einseitig bedienbar	operated from one side	comando da un lato	utilisable d'un côté						
W		an Wand stehend	against wall	contro la parete	contre cloison						

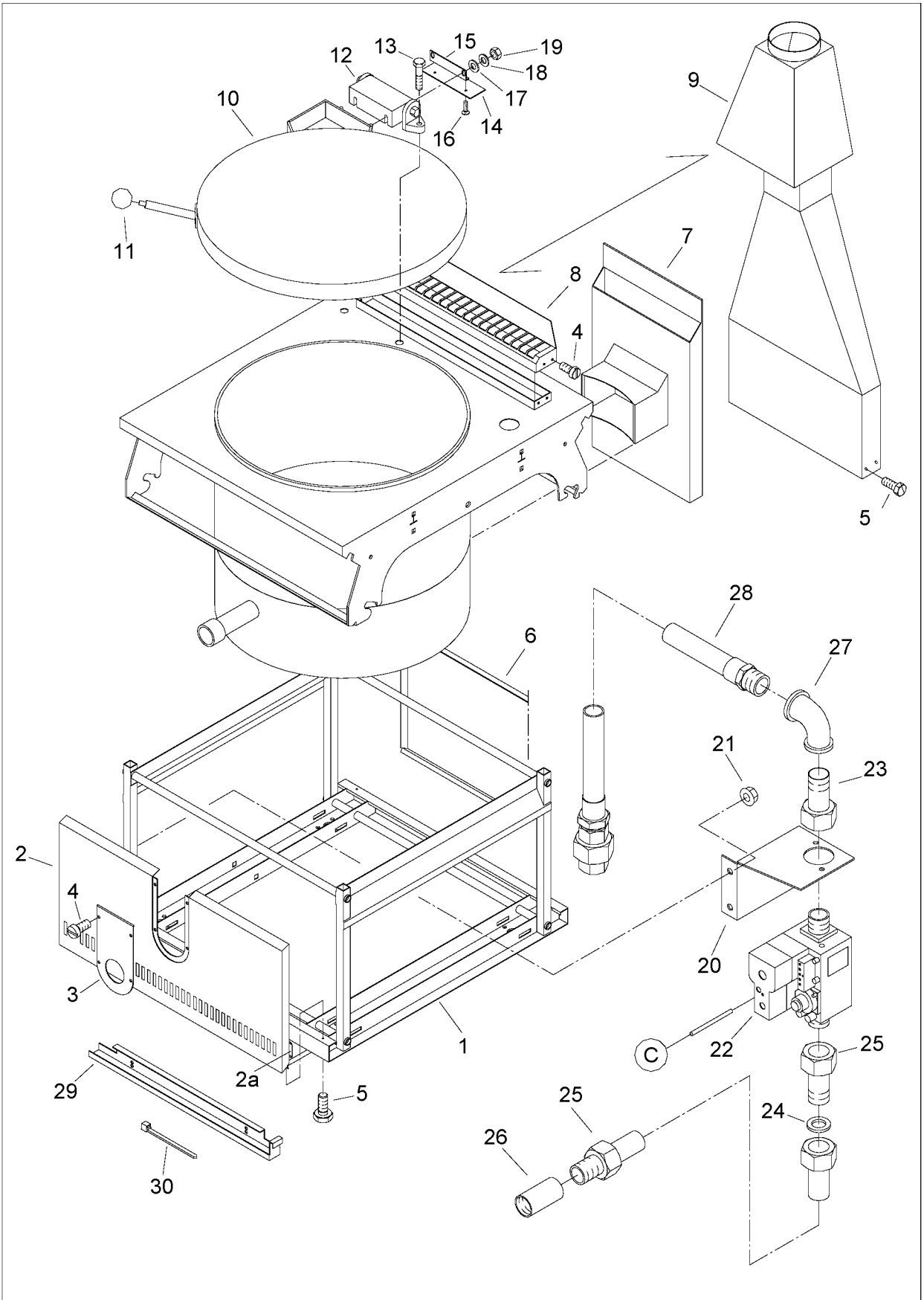



62.9681.02-1		DE	GB	IT	FR						
		Bezeichnung	designation	designazione	désignation						
		Standkochkessel, Gas	stationary boiling pan, gas	pentola fissa, gas	marmite fixe, gaz	60l		80l		100l	
Pos.	Product No.	Gestell	frame	telaio	cadre	E	W	E	W	E	W
1	77.0707	Gestell 700mm	frame 700mm	telaio 700mm	cadre 700mm	1	1				
	77.0708	Gestell 800mm	frame 800mm	telaio 800mm	cadre 800mm			1	1		
	77.0709	Gestell 900mm	frame 800mm	telaio 800mm	cadre 800mm					1	1
2	77.4700	Frontblende 700mm	front panel 700mm	lamiera frontale 700mm	tôle frontale 700mm	1	1				
	77.4701	Frontblende 800mm	front panel 800mm	lamiera frontale 800mm	tôle frontale 800mm			1	1		
	77.4702	Frontblende 900mm	front panel 800mm	lamiera frontale 800mm	tôle frontale 800mm					1	1
2a	77.4705.01	Strahlwasserschutz	water jet protection	protezione del getto di acqua	protection de jet d'eau	1	1				
	77.4705.02	Strahlwasserschutz	water jet protection	protezione del getto di acqua	protection de jet d'eau			1	1		
	77.4705.03	Strahlwasserschutz	water jet protection	protezione del getto di acqua	protection de jet d'eau					1	1
3	77.1112.01	Abschlussdeckel	end cover	coperchio di chiusura	couvercle de recouvre	1	1				
	77.1112.02	Abschlussdeckel	end cover	coperchio di chiusura	couvercle de recouvre			1	1		
	77.1112.04	Abschlussdeckel	end cover	coperchio di chiusura	couvercle de recouvre					1	1
4	1 701 1069	Schraube M5X12	screw M5X12	vite M5X12	vis M5X12	5	5	5	5	5	5
5	1 701 2604	Schraube M6x50	screw M6x50	vite M6x50	vis M5X12	2	2	2	2	2	2
6	62.4068	Rückwand 700 mm	rear panel 700 mm	parete posteriore 700 mm	paroi arrière 700 mm	1					
	62.4006	Rückwand 800 mm	rear panel 800 mm	parete posteriore 800 mm	paroi arrière 800 mm			1			
	62.4007	Rückwand900 mm	rear panel 900 mm	parete posteriore 900 mm	paroi arrière 900 mm					1	
7	77.4708	Kamin	flue	camino	cheminée	1	1				
	76.4868	Kamin	flue	camino	cheminée			1	1		
	77.4713	Kamin	flue	camino	cheminée					1	1
8	76.4861	Rost	grill	gratella	grille	1	1				
	76.4860	Rost	grill	gratella	grille			1	1	1	1
9	76.4927.01	Kamin	flue	camino	cheminée	1	1				
	76.4927.02	Kamin	flue	camino	cheminée			1	1	1	1
10	76.4439.01	Deckel	lid	coperchio	couvercle	1	1				
	70.0751.02	Deckel	lid	coperchio	couvercle			1	1		
	70.0751.05	Deckel	lid	coperchio	couvercle					1	1
11	10 2673	Kugelgriff	ball handle	manetta a pomello	poignée à boule	1	1	1	1	1	1
12	70.0750.02	Scharnier	hinge	cerniera	charnière	1	1				
	70.0750.03	Scharnier	hinge	cerniera	charnière			1	1	1	1
13	1 701 2612	Schraube M10x30	screw M10x30	vite M10x30	vis M10x30	2	2	2	2	2	2
14	70.0765.01	Abdeckblech	cover panel	lamiera di copertura	tôle de couverture	1	1	1	1	1	1

62.9681.02-1		DE	GB	IT	FR						
		Bezeichnung	designation	designazione	désignation						
		Standkochkessel, Gas	stationary boiling pan, gas	pentola fissa, gas	marmite fixe, gaz	60l		80l		100l	
Pos.	Product No.	Gestell	frame	telaio	cadre	E	W	E	W	E	W
15	70.0764	Winkel	angle	angolo	angle	1	1	1	1	1	1
16	1 701 1541	Becherschraube M4x10	screw M4x10	vite M4x10	vis M4x10	2	2	2	2	2	2
17	1 701 3513	Unterlagscheibe M8	washer M8	rondella M8	rondelle M8	2	2	2	2	2	2
18	1 701 5008	Federring M8	spring ring M8	anello della molla M8	anneau de ressort M8	2	2	2	2	2	2
19	1 701 3044	Mutter M8	nut M8	dado M8	écrou M8	2	2	2	2	2	2
20	77.4732	Halter	support	sostegno	fixation	1	1	1	1	1	1
21	712 044 120.06	Kepsmutter M6	capture nut M6	dado M6	écrou M6	2	2	2	2	2	2
22	1 105 1260	Gasventil	gas valve	valvola del gas	vanne de gaz	1	1	1	1	1	1
23	712 344 869.24	Verschraubung G3/4"-G1/2"	screwing G3/4"-G1/2"	collegamento G3/4"-G1/2"	vissage G3/4"-G1/2"	2	2	2	2	2	2
24	712 044 481.24	Dichtung G1/2"	sealing G1/2"	guarnizione G1/2"	joint G1/2"	1	1	1	1	1	1
25	1 117 1238	Schlauch G1/2"	hose G1/2"	tubo flessibile G1/2"	tuyau flexible G1/2"	1	1	1	1	1	1
26	712 344 852.24	Muffe G1/2"	sleeve G1/2"	manicotto G1/2"	manchon G1/2"	1	1	1	1	1	1
27	1 116 1169	Winkel G3/4"-G1/2"	angle G3/4"-G1/2"	angolo G3/4"-G1/2"	angle G3/4"-G1/2"	1	1	1	1	1	1
28	76.2712.02	Rohr Flex ND20 G1"-G3/4"	tube ND20 G1"-G3/4"	tubo ND20 G1"-G3/4"	tuyau ND20 G1"-G3/4"	1	1	1	1	1	1
29	77.9703.01	Kabelhalter	cable tree support	sostegno di cavi	fixation de câbles	1	1				
	77.9703.02	Kabelhalter	cable tree support	sostegno di cavi	fixation de câbles			1	1		
	77.9703.03	Kabelhalter	cable tree support	sostegno di cavi	fixation de câbles					1	1
30	1 115 1391	Kabelbinder	cable binder	raccoglitore del cavo	reliure de câble	6	6	6	6	8	8
<b>E</b>		<b>einseitig bedienbar</b>	<b>operated from one side</b>	<b>comando da un lato</b>	<b>utilisable d'un côté</b>						
<b>W</b>		<b>an Wand stehend</b>	<b>against wall</b>	<b>contro la parete</b>	<b>contre cloison</b>						

## Stationary boiling pan Gas heated 100 Liter (21.0 kW) thermaline S90

	Gas type	Nominal pressure	Category	Main flame		Air adjustment	Servo-Pressure Regulator	SLOW OPENING
				mm	No.	Distance X	mbar	degree
Natural gases	1 Natural gas H	18-20 / 20	2H	3.90	71.4160.390	18	10.0	0
	2 Natural gas E	20	2E	3.90	71.4160.390	18	10.0	0
	3 Natural gas H / L	20 / 25	2+	3.90	71.4160.390	18	inactive	0
	4 Natural gas L	25	2L	3.90	71.4160.390	18	15.0	0
	5 Natural gas LL	20	2LL	3.90	71.4160.390	18	15.0	0
Liquid gases	6	30	3P	2.40	71.4160.240	15	inactive	180
	7 Propane	37	3P	2.30	71.4160.230	15	inactive	180
	8	50	3P	2.10	71.4160.210	15	inactive	180
	9	28 - 30	3B/P	2.30	71.4160.230	15	inactive	180
	10 Butane/Propane	50	3B/P	1.95	71.4160.195	11	inactive	180
	11 Butane/Propane	28-30 / 37	3+	2.30	71.4160.230	15	inactive	180
	12 Pressure pair	50 / 67	3+	1.95	71.4160.195	11	inactive	180

